

MEDIUM VELOCITY GAS BURNERS

MODEL : **NAMG
&
AMG**

BULLETIN: 102
Page 1 of 7

NAMG & AMG Gas burners are widely used on heat treat and melting furnaces, kilns, ovens, air heaters, dryers, chemical process equipment, and other applications where superior temperature uniformity is required.

These sealed - in, nozzle - mix burners for gas are stable on stoichiometric Ratio, with large amounts of excess air, or with up to 50% excess fuel (provided additional air for combustion is in the furnace near the burner.)

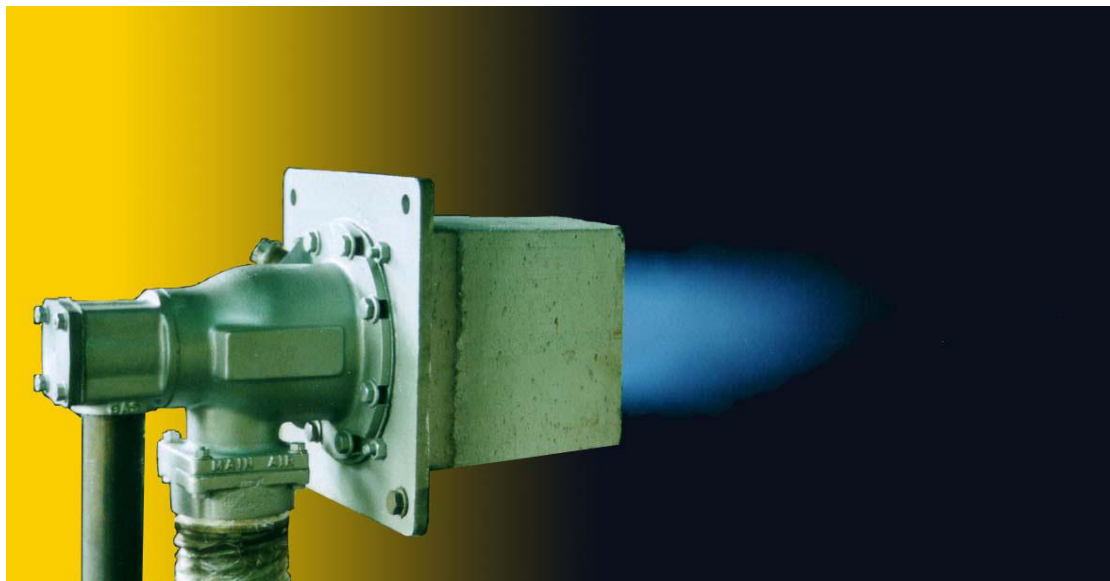

OPERATION

Burners can be lighted at rich, lean, or correct air/fuel ratio, then immediately turned to high fire. Required gas pressures are low for natural gas.

The most common ratio control system for these burners uses a cross-connected governor. When appropriate for the application, flow balancing systems or fuel only control (see "Excess Air" paragraph) is very satisfactory.

If furnace temperatures (after shutdown) rise above 1000 °C, pass some air through burner to prevent overheating.

LIGHTING / FLAME SUPERVISION

A MNG pilot is normally used to light these burners. Direct spark ignition of the burner is also available. Burners accept ultraviolet (UV) scanners for monitoring pilot or main flame. A flame rod can be used to monitor pilot or main flame.

When using flame supervision, an interrupted pilot is required - do not use constant or intermittent pilots. If using direct spark ignition, turn off spark after burner lights.

All burners are furnished with an observation port. A lighter hole cover is supplied if a pilot is not ordered. Position of pilot, flame detector, and observation port are interchangeable as long as pilot and flame detector are mounted in adjacent holes.

SHOLEH SANAT ENG. & MFG. CO.

MANUFACTURER OF BURNERS FOR FURNACES

FUEL CONVERSION OF BOILERS & FURNACES, DESIGN , CONSULTATION AND INSTALLATION

MEDIUM VELOCITY GAS BURNERS

MODEL : **NAMG
&
AMG**

BULLETIN: 102
Page 2 of 7

EXCESS AIR

Excess air improves temperature uniformity by avoiding hot spots in front of burners, churning furnace atmosphere to reduce stratification, and creating positive furnace pressure to eliminate cold air infiltration.

Excess air can give very high effective burner turn down. Thus a furnace used for high temperature work with burners firing on stoichiometric air/fuel ratio can also be used for low temperature jobs with burners firing on lean ratio.

Burner Type	Kcal/hr at 70 mbar (air pressure)	Flame Length(cm) with 70 mbar (air pressure)
		GAS
65NAMG	65,000	45
100NAMG	100,000	60
150NAMG	150,000	75
250NAMG	250,000	75
390NAMG	390,000	120
680NAMG	680,000	180
840NAMG	840,000	180
1100NAMG	1,100,000	210

Burner Type	Kcal/hr at 70 mbar (air pressure)	Flame Length(cm) with 70 mbar (air pressure)
		GAS
30AMG	30,000	40
50AMG	50,000	45
80AMG	80,000	55
1500AMG	1,500,000	230
1900AMG	1,900,000	250
2400AMG	2,400,000	260
3000AMG	3,000,000	300
4500AMG	4,500,000	350
6000AMG	6,000,000	400

CONSTRUCTION FEATURES

Air and gas inlets can be rotated in 90° intervals. Mounting plates are cast iron. For thicker furnace walls, the tunnel beyond the end of tile should be flared at least 30° included angle, starting at tile OD. Extension tiles are not recommend.

For installation convenience, burner body can be separated from the mounting plate and tile assembly. But tile must be set in the wall with pilot and flame detector notches in proper location relative to intended burner body position.

SHOLEH SANAT ENG. & MFG. CO.

MANUFACTURER OF BURNERS FOR FURNACES

FUEL CONVERSION OF BOILERS & FURNACES, DESIGN , CONSULTATION AND INSTALLATION

MEDIUM VELOCITY GAS BURNERS

MODEL : **NAMG**
&
AMG

BULLETIN: 102
Page 3 of 7

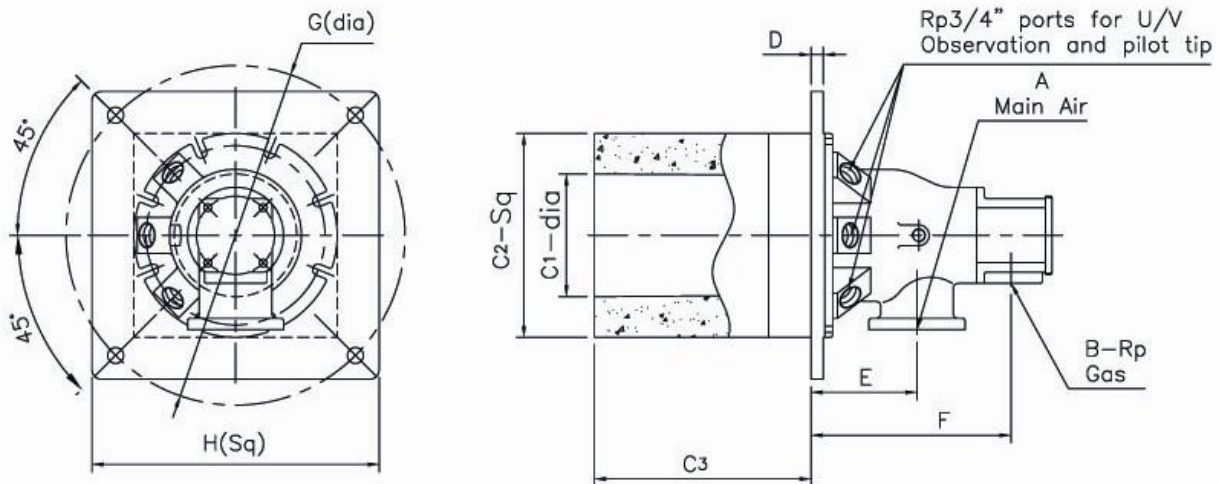

Burner Type	A in	B in	C1 mm	C2 mm	C3 mm	D mm	E mm	F mm	G mm	H mm
65 NAMG	1.1/2	3/4	130	216	230	13	114.5	215.5	360	305
100 NAMG	1.1/2	3/4	130	216	230	13	114.5	215.5	360	305
150 NAMG	2	1	130	216	230	13	114.5	215.5	360	305
250 NAMG	3	1.1/2	130	216	230	13	114.5	215.5	360	305
390 NAMG	3	1.1/2	130	216	230	13	114.5	215.5	360	305
680 NAMG	4	2	181	252	230	15	142	282	400	340
840 NAMG	4	2	181	252	230	15	142	282	400	340
1100 NAMG	6	2	181	252	230	15	142	282	400	340

SHOLEH SANAT ENG. & MFG. CO.

MANUFACTURER OF BURNERS FOR FURNACES

FUEL CONVERSION OF BOILERS & FURNACES, DESIGN , CONSULTATION AND INSTALLATION

MEDIUM VELOCITY GAS BURNERS

MODEL : **NAMG
&
AMG**

BULLETIN: 102
Page 4 of 7

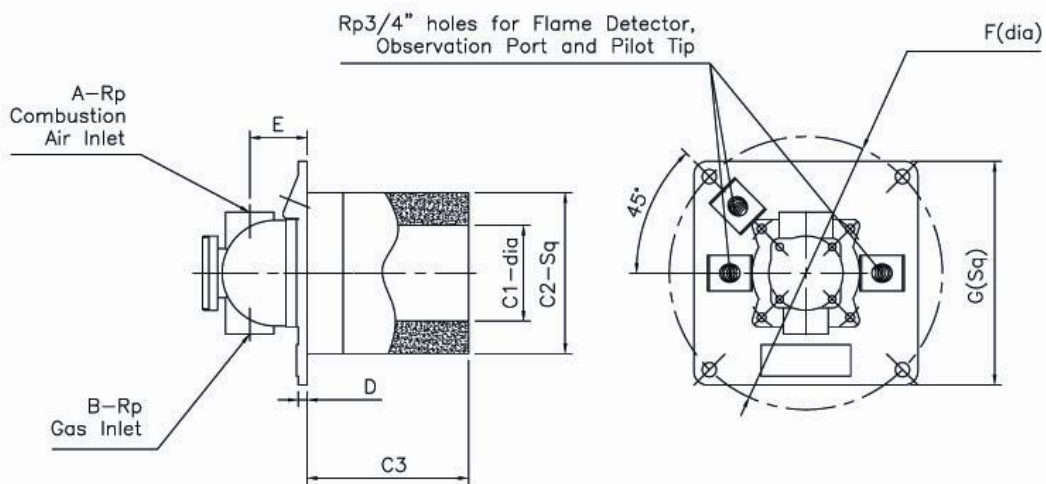

Burner Type	A in	B in	C1 mm	C2 mm	C3 mm	D mm	E mm	F mm	G mm
30 AMG	1.1/2	3/4	107	180	180	10	64.2	305	250
50 AMG	1.1/2	3/4	107	180	180	10	64.2	305	250
80 AMG	1.1/2	3/4	107	180	180	10	64.2	305	250

SHOLEH SANAT ENG. & MFG. CO.

MANUFACTURER OF BURNERS FOR FURNACES

FUEL CONVERSION OF BOILERS & FURNACES, DESIGN , CONSULTATION AND INSTALLATION

MEDIUM VELOCITY GAS BURNERS

MODEL : **NAMG**
&
AMG

BULLETIN: 102
Page 5 of 7

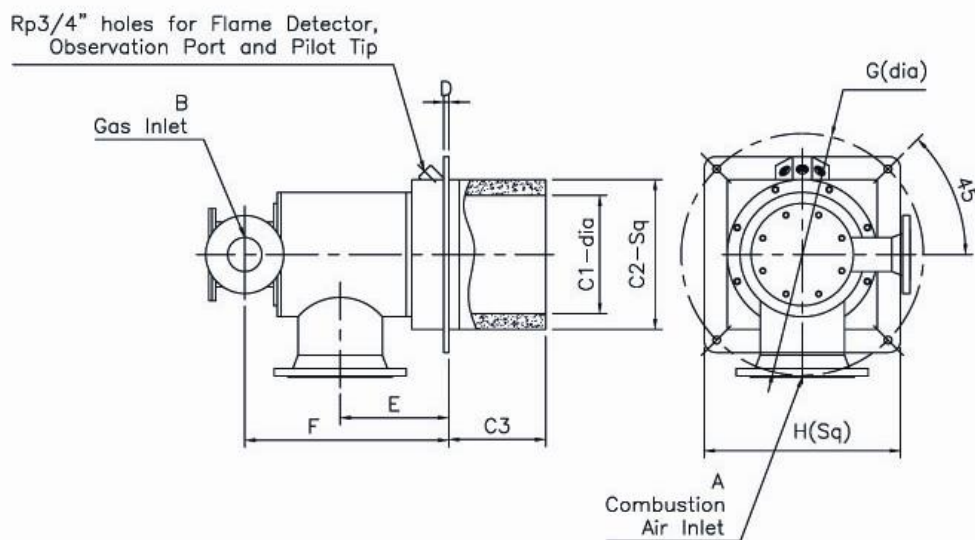

Burner Type	A in	B in	C1 mm	C2 mm	C3 mm	D mm	E mm	F mm	G mm	H mm
1500 AMG	6	2	244	390	252	13	282.5	530.5	630	510
1900 AMG	6	2	308	390	252	13	282.5	530.5	630	510
2400 AMG	8	3	308	390	252	13	282.5	530.5	630	510
3000 AMG	8	3	308	390	252	13	282.5	530.5	630	510
4500 AMG*	10	3	377	457	305	15	465	795	554	600
6000 AMG*	10	3	470	590	400	15	570	982	692	750

* 4500AMG & 6000AMG have circular blocks

SHOLEH SANAT ENG. & MFG. CO.

MANUFACTURER OF BURNERS FOR FURNACES

FUEL CONVERSION OF BOILERS & FURNACES, DESIGN , CONSULTATION AND INSTALLATION

MEDIUM VELOCITY GAS BURNERS

MODEL : **NAMG
&
AMG**

BULLETIN: 102
Page 6 of 7

INSTALLATION

1-Requirements :

- Maximum allowable inlet pressure to the gas governor is 500 mbar. If it is greater than 500 mbar, an upstream pressure regulator must be used.
- Gas supply pressure to the gas governor should be at least 14 mbar greater than the high fire burner air pressure. If less, a bleeder must be installed in the impulse line.
- Consult your SHOLEH SANAT engineer for automatic shut off and flame supervision requirements.

2-Burner Mounting :

- WARNING :** Burners cannot be rotated with respect to the mounting plate as the pilot and flame detector ports must align with notches in the plate.
- To minimize leaks around the tile and to prevent tile damage from thermal expansion of the wall, follow the instructions of SHOLEH SANAT.

3-Piping :

- Minimize piping pressure losses. Use a minimum of elbows. Substitute 45° elbows for 90° elbows if possible. Do not use street elbows. Use pipe (not tubing) for pilot air and gas lines. 1/4" tubing may be used for impulse lines up to 3 m long, 1/2" tubing or larger for longer runs.
- Pipe lines in a manner similar to that shown in Figure 1. Flexible connections are recommended in air and fuel lines to minimize strain from piping and thermal expansion.
- Pilot air, gas supply connections must be made upstream of primary burner controls so that they are not affected by the zone air control and gas shutoff valves.
- Connect impulse piping as shown in Figure 1. These piping arrangements are designed to keep air and gas flows on desired ratio at all firing rates.
- Ratio regulator impulse line connections must be be located between the zone control air valve and the manual burner air valve for multiple burner zones and downstream of the manual burner air valve for single burners.

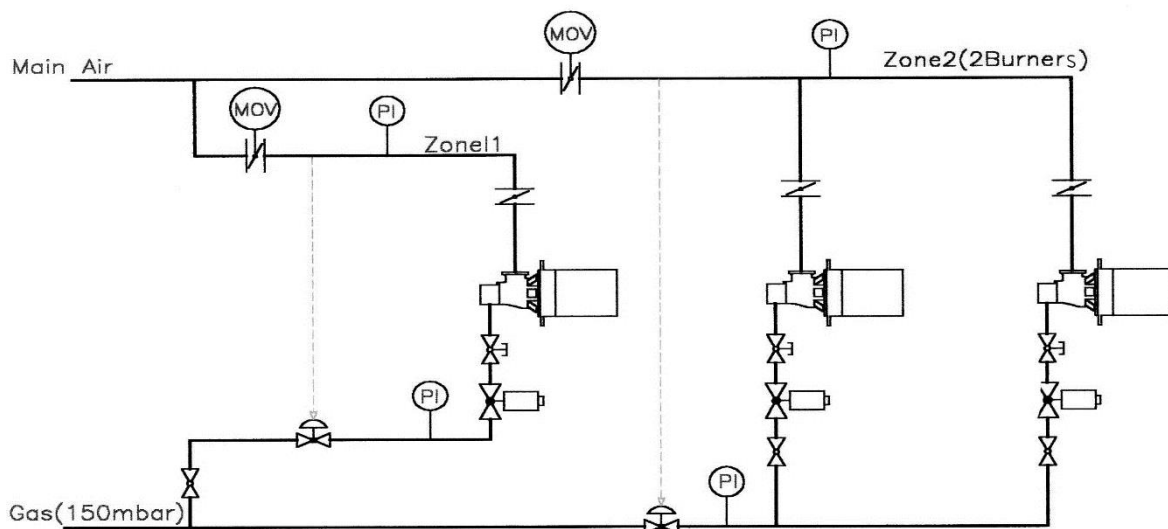

Fig 1 Suggested Piping Arrangement for NAMG & AMG Burners

SHOLEH SANAT ENG. & MFG. CO.

MANUFACTURER OF BURNERS FOR FURNACES

FUEL CONVERSION OF BOILERS & FURNACES, DESIGN , CONSULTATION AND INSTALLATION

MEDIUM VELOCITY GAS BURNERS

MODEL : **NAMG
&
AMG**

BULLETIN: 102
Page 7 of 7

LIGHTING AND ADJUSTMENT

1-Basic

- a) All manual and automatic gas valves must be closed.
- b) Open all furnace doors and flue dampers. Lock all burner air valves in full open position.
- c) Start combustion air blower and check rotation.
- d) Adjust damper motor/air valve linkage (s) for low and high fire.
- e) Set damper motor(s) at high fire allowing furnace to purge for several minutes prior to lighting. Check motor amps with all burners at high fire. If in overload, adjust the linkage to reduce the high fire air flow.
- f) Return the damper motor to low fire. Linkage must not bind.

2 - Light the pilots in accordance with the pilot instruction sheet.

- a) Open gas adjustable valve fifty percent (ADV) from full closed position.
- b) Open gas shutoff valve(s). If burner does not light within a few seconds, close gas shutoff valve and open adjustable valve one more turn, then open gas shutoff valve. Repeat as necessary until burner lights.
- c) Slowly open main air valve to high fire position, adjustable valve as necessary.
- d) Return control valve to low fire position, adjust gas governor for desired flame .
- e) Repeat steps (c) and (d) if necessary.

3 - Trouble shooting :

- a) Gas supply pressure too high or too low (see appropriate regulator literature).
- b) Impulse pressure too low to gas governor - check for dirt in line or connections, check method of connecting impulse line to air pipe.
- c) Governor not controlling -check method of connecting impulse line to air pipe, check governor diaphragms (see governor literature), if bleeder is used, check orifices for dirt.

Head Office

Unit 8, No.36, Bozorgmehr St. Valiasr Ave,
Tehran, Iran.

Tel : (++98 21) 66405859,66409443

Fax: (++98 21) 66402118

info@sholehsanat.com

www.sholehsanat.com

Factory

8th Ave., 1st Industry Blvd., Rasht Industrial
City, Rasht, Iran.

Tel : (++98 13) 33882063

Fax: (++98 13) 33882502

factory@sholehsanat.com

SHOLEH SANAT ENG. & MFG. CO.

MANUFACTURER OF BURNERS FOR FURNACES

FUEL CONVERSION OF BOILERS & FURNACES, DESIGN , CONSULTATION AND INSTALLATION